

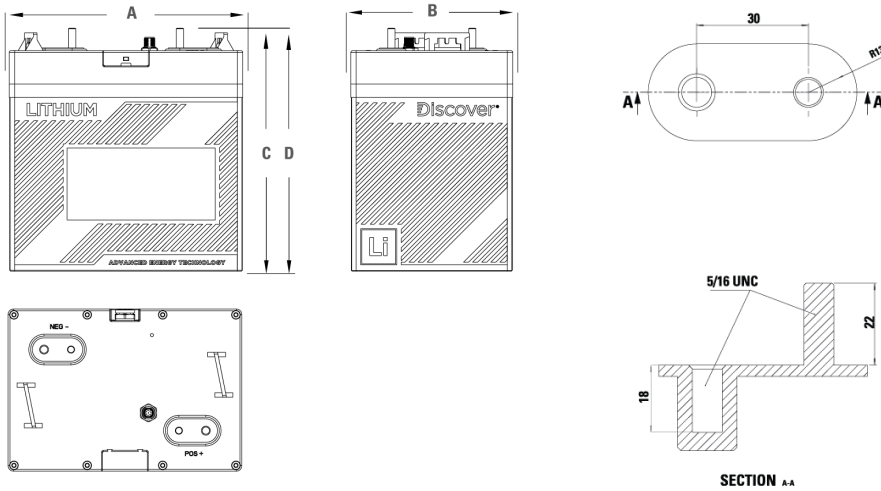

## LITHIUM PROFESSIONAL Battery

Discover® AES PROFESSIONAL LiFePO<sub>4</sub> battery models are purpose built to replace and fit the standard groupings of BCI 6V, 8V and 12V (GC) batteries. AES PROFESSIONAL batteries incorporate a proprietary high-current BMS that delivers superior peak power along with lightning fast 1C continuous charge and discharge rates, plus they feature COLD CHARGE functionality allowing for cold temperature charging to begin from -20°C / -4°F. Independently tested to the highest safety, performance and transportation standards, a single battery will do the work of many lead-acid batteries and unlike lead-acid batteries can be continuously operated in a Partial State of Charge (PSOC) without degrading performance.



## MECHANICAL SPECIFICATIONS

Industry Reference	BCI: GC2	
Length A (in/mm)	10.2	260
Width B (in/mm)	7.1	180
Height C (in/mm)	10.0	254
Total Height D (in/mm)	10.8	275
Weight (lbs/kgs)	30.7	14.0
Terminal *	BM 5/16	
Cell(s)	Prismatic 16S1P	
Case Material	UL94-VO PBT/PC	
IP Rating	67	
Electrolyte	LiFePO <sub>4</sub>	

NOTE 1: Dimensions have a ±2 mm (0.08 in) tolerance. Weights may vary.

NOTE 2: Refer to terminal guide on website for torque values.

## ELECTRICAL SPECIFICATIONS

Open Circuit Voltage (V)	51.2
Charge Voltage (Bulk Vdc)	55.2 - 56.8
Max Absorption Voltage (U1 Vdc)	55.2
Float Voltage (U2 Vdc)	53.6
BMS Max. Voltage protection (Vdc)	58.4 (Approximately)
Suggested Low Voltage Cutoff (Vdc) *	
BMS Min. Voltage protection (Vdc)	40.0 (Approximately)
Max. Continuous Charge Current (I Max. Adc)	29
Min. Finishing Charge Current (I Min. Adc)	2%-3% C1 / Min. 200ma
Max Continuous Discharge Current (Adc)	58
Max Peak Current (Adc)	90 A RMS (3 sec)
Self-Discharge (25°C / 77°F)	< 3% per month
Charge Temperature	Min: -20°C (-4°F)   Max: 45°C (113°F)
Discharge Temperature	Min: -20°C (-4°F)   Max: 55°C (131°F)
Storage Temperature	Min: -10°C (14°F)   Max: 30°C (86°F)

Electrical Specifications at 25°C.

\* Do not exceed maximum voltage at the battery terminals.

CAUTION: Extra considerations must be given to depths of discharge, operating voltages and currents when designing systems for use at maximum operating temperatures.

## FEATURES

### LYNK PORT

- Connects battery string to LYNK Gateway
- Plug and Play Multi-battery BMS communication
- J1939 Protocol
- Remote ON / OFF Capable

### HIGH-PERFORMANCE BMS

- Up to 3C peak power for inverters and motor controllers
- Discharge current up to 2C
- Continuous charge current up to 1C
- Sets voltage, broadcasts, SoC and temperature
- External field replaceable fuse protection

### COLD CHARGING

- Integrated self-heating

### STATUS VIEW

- ON / OFF multi-color status LED

## ACCESSORIES

### LYNK II GATEWAY

- Closed-loop communications with chargers and motor controllers
- CAN Open / Serial CAN
- Programmable relays for LVCO, Load Shedding
- SD Memory
- Download Battery Data

### LYNK LITE GATEWAY

- Closed-loop communications with chargers and motor controllers
- CAN Open / Serial CAN
- Download Battery Data
- IP 65

### BATTERY DISCHARGE INDICATOR

- At-a-glance SoC display

## BENEFITS

### RUNS LONGER

- 2x the high-current runtime of lead-acid battery
- Up to 100% usable capacity
- Easy to parallel more capacity

### LASTS LONGER

- 10x the life of lead-acid battery (BCI-06)
- Unlimited Partial State of Charge cycles
- Energy throughput warranty

### CHARGES FASTER

- Up to 5x faster than new lead-acid batteries
- 2x faster than C/2 rated lithium batteries
- Opportunity charge at 1C rate anytime, regardless of SoC

### SURGE POWER

- High 3C Peak Power
- Discharge Current up to 2C

### HIGH-EFFICIENCY

- Up to 50% more energy efficient than a lead-acid battery
- Up to 98% round-trip efficiency

### PARALLEL POWER

- Easy to parallel more capacity
- Linear scaling of charge, discharge and peak capacity

### QUICK INSTALL

- Fast installation
- No special tools

### RELIABLE AND SAFE

- LiFePO<sub>4</sub> is safe
- Maintenance-free
- UL94-5VA flame retardant case and cover
- IP 67 rated

### CERTIFIED QUALITY

Discover® manufacturing facilities are fully certified to ISO 9001/14001 and OSHA 18001 standards.

### CERTIFICATION STANDARDS

- IEC 62619
- UL 2271
- CE
- UN 38.3

## SHIPPING CLASSIFICATION

- UN 3480, Class 9 (Lithium batteries)

# PERFORMANCE SPECIFICATIONS

Nominal Energy (kWh)	1.54	<b>Minutes of Discharge</b>				
Usable DoD	100%	@25A	@56A	@75A	@85A	@100A
Rated Wh Capacity (1C)	1536	72	32	24	21	18
Rated Ah Capacity (1C)	30					

## Fast Charging at .5C (2HR) to 1C (1HR)

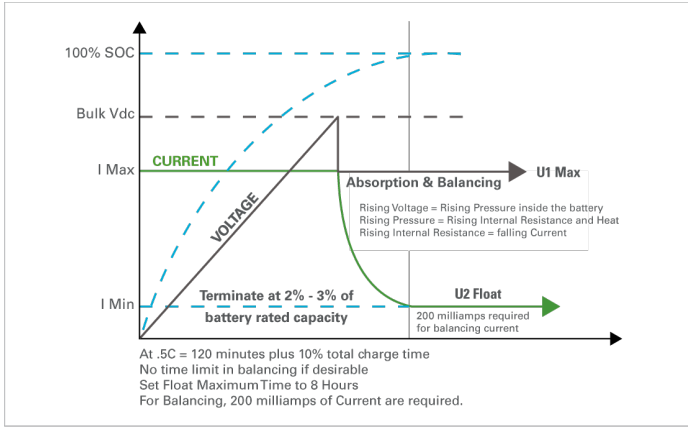

## Standard to Low Rate Charging at .2C (5HR) to .5C (2HR)

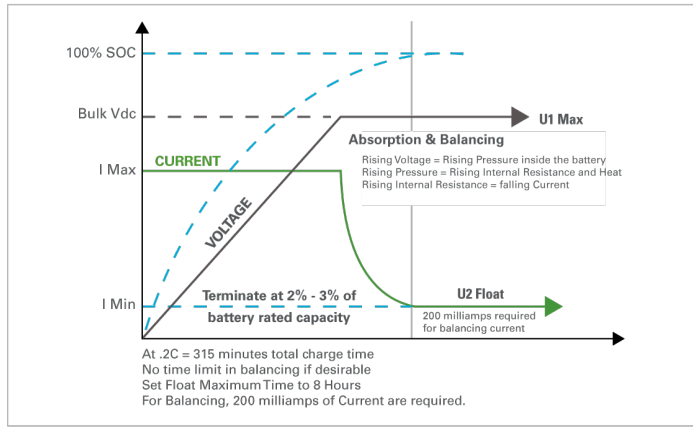

## Voltage in Relation to Rate of Discharge

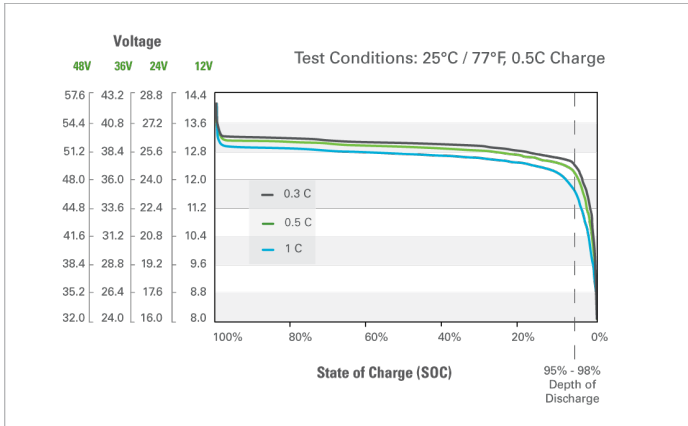

## Discharge Voltage and Capacity vs. Temperature

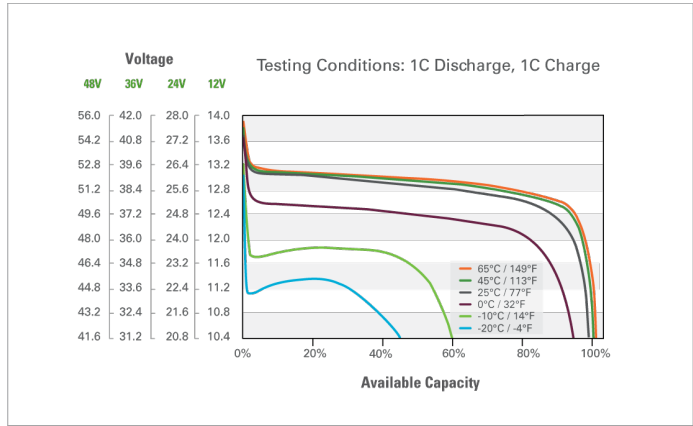

## Charge Performance (Lithium vs. Lead)

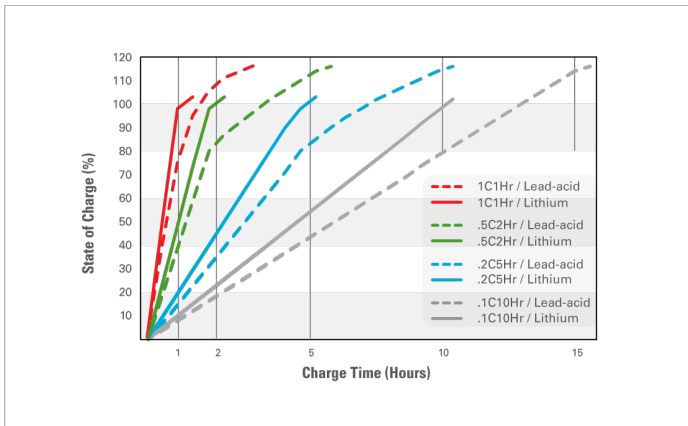

## Discharge Performance (Lithium vs. Lead)

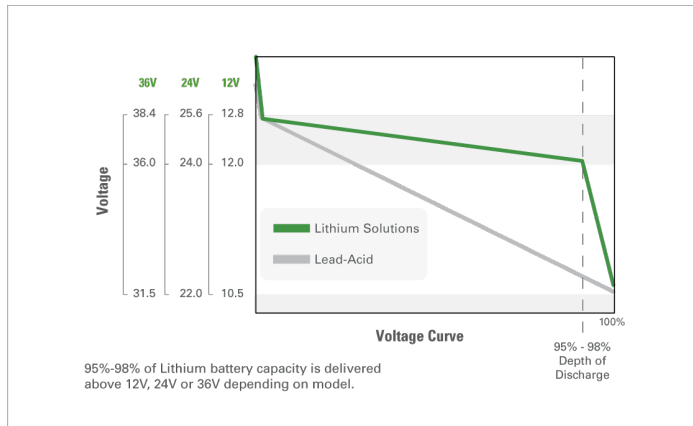

### NOTES

**CAUTION:** Direct connection to DC motors without proper safety protection, motor controllers, and external motor voltage clamping systems (such as high power anti-parallel diodes or braking resistor systems) may result in damage to the internal pack protection system which may result in unsafe situations. Please consult Discover technical support before directly connecting any motorloads.

Discover® reserves the right to make adjustments to this publication at any time, without notice or obligation. Data in this publication are for reference use only and models may vary from shown. It is the responsibility of the reader of this information to verify any and all information presented herein. For more information contact us at [info@discoverbattery.com](mailto:info@discoverbattery.com)