



# Apollo™ RA770 Installation Instructions

## Important Safety Information

### ⚠ WARNING

Failure to follow these warnings and cautions could result in personal injury, damage to the vessel, or poor product performance.

See the *Important Safety and Product Information* guide in the product box for product warnings and other important information.

This device must be installed according to these instructions.

Disconnect the vessel's power supply before beginning to install this product.

Before applying power to this product, make sure it has been correctly grounded, following the instructions in the guide.

### ⚠ CAUTION

To avoid possible personal injury, always wear safety goggles, ear protection, and a dust mask when drilling, cutting, or sanding.

### NOTICE

When drilling or cutting, always check what is on the opposite side of the surface to avoid damaging the vessel.

Do not use the stereo as a template when drilling the mounting holes because this may damage the glass display and void the warranty. You must only use the included template to correctly drill the mounting holes.

You must read all installation instructions before beginning the installation. If you experience difficulty during the installation, contact Fusion® Product Support.

## What's In the Box

- Mounting gasket
- Four 8-gauge, self-tapping screws
- Two screw covers
- Power and speaker wiring harness
- Auxiliary-in, line-out, and subwoofer-out wiring harnesses
- 2 m (6 ft.) NMEA 2000® drop cable
- Dust cover

## Tools Needed

- Phillips screwdriver
- Electric drill
- Drill bit (size varies based on surface material and screws used)
- Rotary cutting tool or jigsaw
- Silicone-based marine sealant (optional)

## Mounting Considerations

- You must mount the stereo on a flat surface that provides open airflow around the rear of the stereo for heat ventilation.
- If you are installing the stereo in a location that may be exposed to water, you must mount it within 45 degrees below or 15 degrees above the horizontal plane.

- If you are installing the stereo in a location that may be exposed to water, you must add a drip loop to the cable to allow water to drip off of the cable and avoid damage to the stereo.
- If you need to mount the stereo on the outside of the boat, you must mount it in a location far above the waterline, where it is not submerged, and where it cannot be damaged by docks, pilings, or other pieces of equipment.
- To avoid interference with a magnetic compass, you should mount the stereo at least 15 cm (5.9 in.) away from a compass.

## Mounting the Stereo

### NOTICE

Do not use the stereo as a template when drilling the mounting holes because this may damage the glass display and void the warranty. You must only use the included template to correctly drill the mounting holes.

Be careful when cutting the hole to mount the stereo. There is only a small amount of clearance between the case and the mounting holes, and cutting the hole too large could compromise the stability of the stereo after it is mounted.

Be careful when installing the stereo in an aluminum boat or a boat with a conductive hull, if you require the electrical system to be isolated from the boat hull.

Do not apply grease or lubricant to the screws when fastening the stereo to the mounting surface. Grease or other lubricants can cause damage to the stereo housing.

Before you can mount the stereo in a new location on the mounting surface, you must select a location in accordance with the mounting considerations.

- 1 Adhere the template to the mounting surface.
- 2 Drill a hole inside the corner of the dashed line on the template.
- 3 Cut the mounting surface ① along the inside of the dashed line on the template.

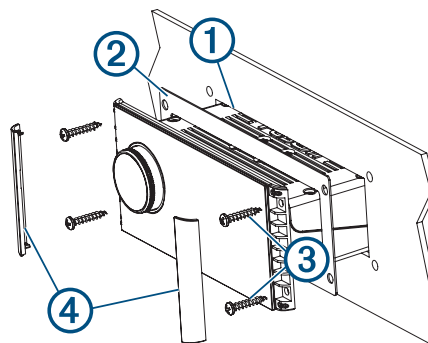

- 4 Ensure the mounting holes on the stereo line up with the pilot holes on the template.
- 5 Using an appropriately sized drill bit for the mounting surface and screw type, drill the pilot holes.
- 6 Remove the template from the mounting surface.
- 7 Complete an action:
  - If you are installing the stereo in a dry location, place the included mounting gasket ② on the back of the stereo.
  - If you are installing the stereo in a location that is exposed to water, apply silicone-based marine sealant on the mounting surface around the cutout.



## NOTICE

Do not install the included mounting gasket if you applied sealant to the mounting surface. Using sealant and the mounting gasket may reduce water resistance.

- 8 If you will not have access to the back of the stereo after installation, make the necessary wiring connections.
- 9 Secure the stereo to the mounting surface using the included screws ③.  
You should hand-tighten the screws when securing the stereo to the mounting surface to avoid over tightening them.
- 10 Snap the screw covers in place ④.

## Connection Considerations

For the stereo to function correctly, you must connect it to power, to speakers, and to input sources. You should carefully plan the layout of the stereo, speakers, input sources, optional NMEA 2000 network, and optional Fusion PartyBus™ devices or network before making any connections.

## Port Identification

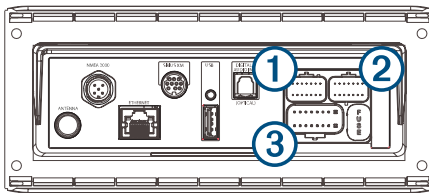

Item	Description
ANTENNA	Connects the stereo to a typical AM/FM antenna. If you are installing the stereo on a boat with a metal hull, you must use a ground-dependent antenna. If you are installing the stereo on a boat with a non-metal hull, you must use a ground-independent antenna. See the installation instructions provided with your antenna for more information.
NMEA 2000	Connects the stereo to a NMEA 2000 network ( <i>NMEA 2000 System Wiring Diagram, page 4</i> ). Connects to an NRX series remote control directly ( <i>Configuring an Optional Wired NRX Remote Control, page 4</i> ).
ETHERNET	Connects the stereo to another Fusion PartyBus stereo, zone stereo, or network ( <i>Fusion PartyBus Networking, page 4</i> ).
SIRIUS XM	Connects the stereo to a SiriusXM® Connect Tuner to receive SiriusXM stations where available (not included). Connects to a Fusion DAB module to receive DAB stations where available (not included).
USB	Connects the stereo to a USB source.
DIGITAL AUDIO IN	Connects the stereo to an optical digital audio source, such as TV or DVD player.
FUSE	Contains the 15 A fuse for the device.
①	Connects the stereo to the wiring harness for auxiliary input 2, and for the line and subwoofer outputs for zones 3 and 4.
②	Connects the stereo to the wiring harness for auxiliary input 1, and for the line and subwoofer outputs for zones 1 and 2.
③	Connects the stereo to the power and speaker wiring harness.

## Wiring Harness Wire and Connector Identification

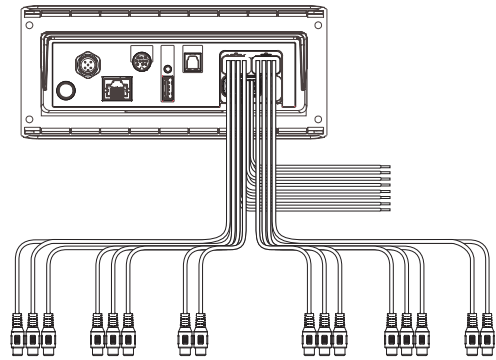

Wire or RCA Connector Function	Bare Wire Color or RCA Label Name	Notes
Ground (-)	Black	Connects to the negative terminal of a 12 Vdc power source capable of supplying 15 A. You should connect this wire before connecting the yellow wire. All accessories connected to the stereo must share a common ground location ( <i>Connecting to Power, page 3</i> ).
Power (+)	Yellow	Connects to the positive terminal of a 12 Vdc power source capable of supplying 15 A.
Ignition	Red	Connects to a separately-switched, 12 Vdc connection, such as an ignition bus, to turn the stereo on and off. If you are not using a switched 12 Vdc connection, you must connect this to the same source as the yellow (power) wire
Amplifier on	Blue	Connects to optional external amplifiers, enabling them to turn on when the stereo turns on. A connected amplifier must use the same ground (-) as the stereo for this signal wire to function correctly.
Telemute	Brown	Activates when connected to ground. For example, when you connect this wire to a compatible, hands-free mobile kit, the audio mutes or the input switches to Aux1 when a call is received and the kit connects this wire to ground. You can enable this functionality from the settings menu.
Dim	Orange	Connects to the boat's illumination wire to dim the stereo screen when the lights are on. The gauge of the illumination wire must be suitable for the fuse supplying the circuit it is connected to.
Speaker zone 1 left (+)	White	
Speaker zone 1 left (-)	White/black	
Speaker zone 1 right (+)	Gray	
Speaker zone 1 right (-)	Gray/black	
Speaker zone 2 left (+)	Green	
Speaker zone 2 left (-)	Green/black	
Speaker zone 2 right (+)	Purple	

Wire or RCA Connector Function	Bare Wire Color or RCA Label Name	Notes
Speaker zone 2 right (-)	Purple/black	
Zone 1 line out (left) Zone 1 line out (right) Zone 1 subwoofer out	ZONE 1 ZONE 1 SUB OUT	Provides output to an external amplifier, and is associated with the volume control for zone 1. Each subwoofer cable provides a single mono output to a powered subwoofer or subwoofer amplifier.
Zone 2 line out (left) Zone 2 line out (right) Zone 2 subwoofer out	ZONE 2 ZONE 2 SUB OUT	Provides output to an external amplifier, and is associated with the volume control for zone 2. Each subwoofer cable provides a single mono output to a powered subwoofer or subwoofer amplifier.
Auxiliary in 1 left Auxiliary in 1 right	AUX IN 1	Provides an RCA stereo line input for audio sources, such as a CD or MP3 player.
Zone 3 line out (left) Zone 3 line out (right) Zone 3 subwoofer out	ZONE 3 ZONE 3 SUB OUT	Provides output to an external amplifier, and is associated with the volume control for zone 3. Each subwoofer cable provides a single mono output to a powered subwoofer or subwoofer amplifier.
Zone 4 line out (left) Zone 4 line out (right) Zone 4 subwoofer out	ZONE 4 ZONE 4 SUB OUT	Provides output to an external amplifier, and is associated with the volume control for zone 4. Each subwoofer cable provides a single mono output to a powered subwoofer or subwoofer amplifier.
Auxiliary in 2 left Auxiliary in 2 right	AUX IN 2	Provides an RCA stereo line input for audio sources, such as a CD or MP3 player.

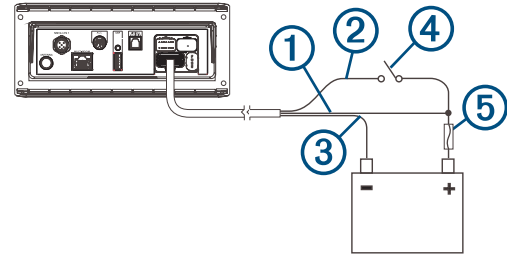

- 2 Connect the black wire to the negative (-) battery terminal.
- 3 If you are routing the red wire through the ignition or another manual switch ④, connect the red ignition wire to the ignition or switch.
- 4 Connect the red wire to the yellow wire, install a 15 A fuse ⑤ as close to the battery as possible, and connect both wires to the positive (+) battery terminal.

**NOTE:** If you are running the red wire through a fused switch, it is not necessary to connect the red wire to the yellow wire or to add an additional fuse to the red wire.

If you connect both the red and yellow wires through a 15 A circuit breaker, it is not necessary to add an additional fuse.

- 5 Connect the wiring harness to the stereo.

### Speaker Zones

You can group speakers in one area into a speaker zone. This enables you to control the audio level of the zones individually. For example, you could make the audio quieter in the cabin and louder on deck.

Up to two speakers can be connected per channel (left and right) of each zone, in parallel. A zone can support no more than four speakers using the on-board amplifier.

Zones 1 and 2 are powered by the on-board amplifier. To use the RCA line outputs and the RCA subwoofer outputs for zones 1 and 2, you must connect external amplifiers.

Zones 3 and 4 are available as line-level outputs only. To use the RCA line outputs and the RCA subwoofer outputs for zones 3 and 4, you must connect external amplifiers.

You can set the balance, volume limit, tone, subwoofer level, subwoofer frequency, and name for each zone, and configure other zone-specific settings.

### Single-Zone System Wiring Example

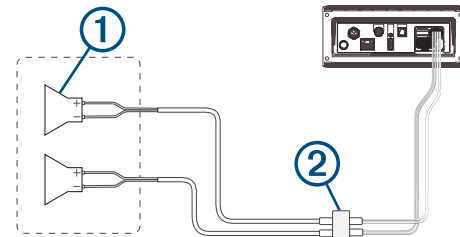

①	Speakers
②	Water-tight connection

### Speaker System Wiring Using a Line Out

This diagram illustrates a system installation with an external amplifier and subwoofer connected to zone 2 on the stereo using a line out. You can connect an amplifier and subwoofer to any or all of the available zones on the stereo.

**NOTE:** You can connect speakers to the speaker wires for the internal stereo amplifier while using the line out on zones 1 and 2, although adjusting the volume affects both the speakers connected to the internal amplifier and the line out. This may result in uneven volume levels.

### Connecting to Power

When connecting the stereo to power, you must connect both power wires. The yellow power wire must connect to the battery to provide sufficient power to the stereo. The red ignition should be connected through the ignition or another manual switch to enable on/off control of the stereo. This installation method provides the best performance because the yellow wire retains a constant trickle-power draw that optimizes the startup time for the stereo.

**NOTE:** If you will be storing the vessel for an extended period of time, you should consider connecting the yellow wire through a breaker or similar switch, so you can disconnect the trickle-power draw from the yellow wire and avoid draining the battery during storage.

If you do not have the option of, or prefer not to use the ignition to turn the stereo on and off, you can connect the red wire and the yellow wire to the same switch on an electrical panel. This installation method results in a slightly longer startup time for the stereo, but it will not draw power from the battery when the stereo is turned off using the switch.

You must connect the power wires to the battery through a 15 A fuse or a 15 A circuit breaker.

If it is necessary to extend the yellow power and black ground wires, use 14 AWG (2.08 mm<sup>2</sup>) wire. For extensions longer than 1 m (3 ft.), use 12 AWG (3.31 mm<sup>2</sup>) wire.

If it is necessary to extend the red ignition wire, use 22 AWG (0.33 mm<sup>2</sup>) wire.

- 1 Route the yellow power ①, red ignition ②, and black ground ③ wires to the battery, and route the wiring-harness plug to the stereo.

Do not connect the wiring harness to the stereo until all of the bare wire connections have been made.

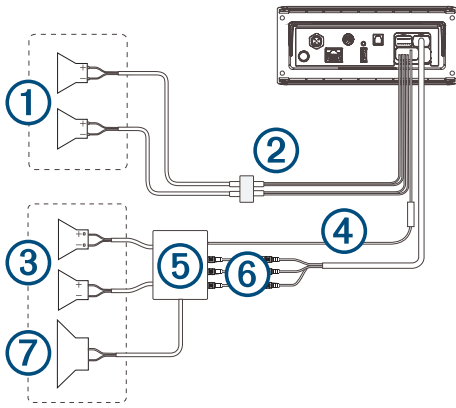

①	Zone 1 speakers
②	Water-tight connection
③	Zone 2 speakers
④	Amplifier-on signal wire You must connect this wire to each amplifier connected to a zone line out. A connected amplifier must use the same ground (-) as the stereo for this signal wire to function correctly.
⑤	Powered amplifier connected to the zone 2 line out
⑥	Zone 2 line out and subwoofer out Each subwoofer cable provides a single mono output to a powered subwoofer or subwoofer amplifier. You may need to use an RCA splitter to connect this to an amplifier.
⑦	Subwoofer

## NMEA 2000 System Wiring Diagram

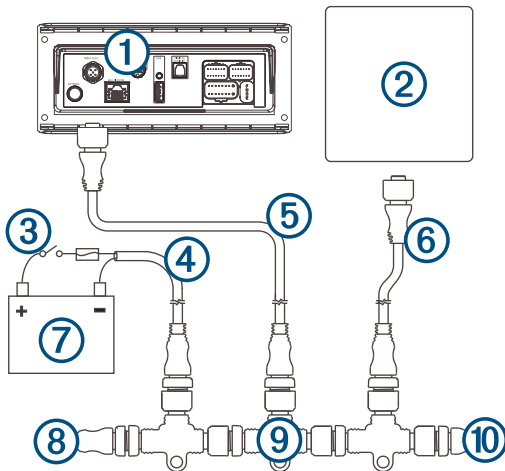

①	Stereo
②	Supported chartplotter MFD or compatible Fusion NMEA 2000 remote control
③	In-line switch
④	NMEA 2000 power cable
⑤	NMEA 2000 drop cable from the stereo, up to 6 m (20 ft.)
⑥	NMEA 2000 drop cable from the chartplotter MFD or compatible Fusion NMEA 2000 remote control
⑦	9 to 16 Vdc power supply
⑧	NMEA 2000 terminator or backbone cable
⑨	NMEA 2000 T-connector
⑩	NMEA 2000 terminator or backbone cable

## Configuring an Optional Wired NRX Remote Control

### NOTICE

The stereo is configured by default to work with a NMEA 2000 network, and the NRX POWER option should be enabled only when an optional wired NRX remote control is connected directly to the stereo. Enabling this option when the stereo is connected to a NMEA 2000 network may damage other devices on the NMEA 2000 network.

If you connect an optional wired NRX remote control directly to the stereo, and not through a NMEA 2000 network, additional configuration is needed.

1 Select > **SETTINGS** > **POWER OPTIONS**.

2 Select an option:

- If you connected both your stereo and your optional wired remote to a NMEA 2000 network, make sure the **NRX POWER** option is not selected. This enables the optional remote to receive power from the NMEA 2000 network.
- If you connected the optional wired remote directly to the stereo through the NMEA 2000 connector, select the **NRX POWER** option. This enables the stereo to supply power to the optional remote.

## Fusion PartyBus Networking

The Fusion PartyBus networking feature allows you to connect multiple compatible stereos together on a network, using a combination of wired or wireless connections.

You can group a compatible stereo, such as the Apollo RA770 stereo, with other compatible stereos connected to the network. Grouped stereos can share available sources and control media playback on all of the stereos in the group, which allows for a synchronized audio experience across the vessel. You can quickly create, edit, and break up groups as needed from any compatible stereo or remote control on the network.

**NOTE:** A zone stereo, such as the Apollo SRX400, can create or join a group to control and play sources from other stereos, but it cannot share its sources with the group.

For additional considerations when sharing sources, see the owner's manual.

You can use compatible stereos and remote controls, whether they are grouped or not, to adjust the volume of the available speaker zones for any stereo on the network.

You can connect up to eight Fusion PartyBus stereos on a network wirelessly.

## Wired Networking Considerations

When you are planning your network installation, observe the following considerations for all wired connections.

- You must connect devices using standard Cat5e or Cat6 network cables with RJ45 connectors.
- You can use one network cable to directly connect two compatible devices.
- You must use wired network switches and wired or wireless network routers when you connect more than two compatible devices to a network.
- If you install a router on the network, it should be configured to be a DHCP server by default. See your router instructions for more information.
- If you do not install a router, and there are no other DHCP servers on the network, you should configure one Fusion PartyBus stereo to be a DHCP server ([Setting the Fusion PartyBus Device as the DHCP Server, page 6](#)).

## Wired Network Example for Direct Connections

No network setting changes are needed when connecting two devices together directly, but for the best results, you should

configure one device to be a DHCP server (*Setting the Fusion PartyBus Device as the DHCP Server, page 6*).

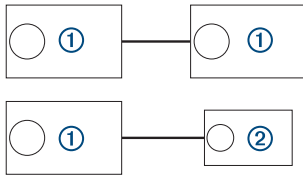

①	Fusion PartyBus stereo
②	Fusion PartyBus zone stereo or remote control

### Wired Network Example with a Switch or Router

You must use wired network switches, a wired network router, or both to connect more than two devices.

If you did not install a router, and there are no other DHCP servers on the network, you should configure one Fusion PartyBus stereo to be a DHCP server (*Setting the Fusion PartyBus Device as the DHCP Server, page 6*). If you installed a router, you may need to configure it to be a DHCP server. See your router instructions for more information.

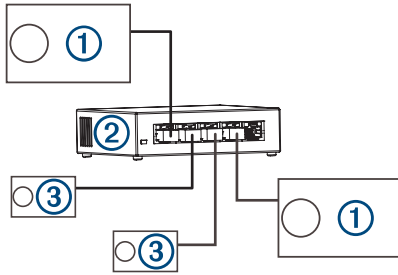

①	Fusion PartyBus stereo
②	Wired network switch or wired network router
③	Fusion PartyBus zone stereo or remote control

### Wireless Networking Considerations

When you are planning your network, observe the following considerations for all wireless connections.

- Wired connections are more reliable than wireless connections. You should plan your network to use network cables, but if it is not possible, many Fusion PartyBus devices are Wi-Fi® compatible. You can connect them to wireless routers or access points.
- If you install a wireless router on the network, it should be configured to be the DHCP server by default. See your wireless router instructions for more information.
- If you are not using a wireless router, you can configure this device as a wireless access point, so you can connect other devices within wireless range.

**NOTE:** You should not configure this device as a wireless access point if you have a router installed on the network, because it may introduce DHCP conflicts and result in poor network performance.

- If you connect a Fusion PartyBus device to the network as a WI-FI CLIENT, you cannot connect any additional wired Fusion PartyBus devices to that device.
- You can connect a smartphone to the wireless network to control any stereo on the network using the Fusion-Link™ app.
- You can connect an Apple® device to the wireless network to stream media to multiple stereos on the network using Apple AirPlay® 2.
- Connecting a Bluetooth® device to the stereo may interfere with some Wi-Fi connections.

- Wi-Fi signals may interfere with Bluetooth device connections. You should turn off the Wi-Fi setting on your stereo if you are not using it to connect to a wireless network or to provide a wireless access point.

### Wireless Access Point Example

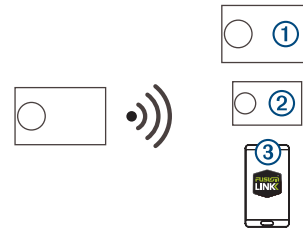

①	Fusion PartyBus stereo
②	Fusion PartyBus zone stereo
③	Smartphone using the Fusion-Link app

### Wireless Network Example with a Wired Switch or Router

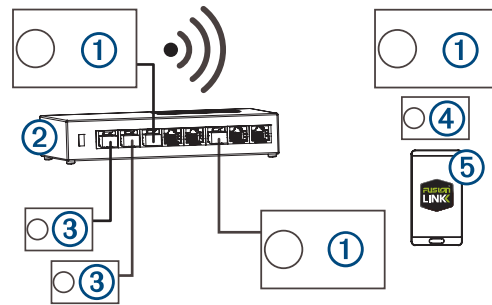

①	Fusion PartyBus stereo
②	Wired network switch or wired network router
③	Fusion PartyBus zone stereo or remote control
④	Fusion PartyBus zone stereo
⑤	Smartphone using the Fusion-Link app.

### Wireless Network Example with a Wireless Router or Access Point

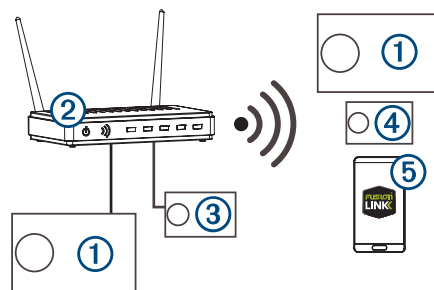

①	Fusion PartyBus stereo
②	Wireless network router or wireless access point
③	Fusion PartyBus zone stereo or remote control
④	Fusion PartyBus zone stereo
⑤	Smartphone using the Fusion-Link app

### Constructing a Network

You should have a basic understanding of networking when building a network for Fusion PartyBus devices.

These instructions guide you through the basics of building and configuring a network, and should apply to most situations. If you need to perform advanced networking tasks, such as assigning static IP addresses to devices on the network or

configuring advanced settings on a connected router, you may need to consult a networking professional.

- 1 Determine the installation location of the Fusion PartyBus devices you want to connect to the network.

**NOTE:** Wired connections are more reliable than wireless connections. When planning your network, you should run network cables instead of using wireless connections when possible.

- 2 Determine the installation location of any needed network routers or switches.
- 3 Route Cat5e or Cat6 network cable to the installation locations of the stereos, switches, and router.
- 4 Connect the network cables to the stereos, switches, and router.

#### NOTICE

Do not completely install the stereos yet. You should test the network before you install the stereos.

- 5 Turn on all devices connected to the network, including wireless devices.
- 6 Select an option:
  - If you are using a network router (wired or wireless), consult the documentation provided with your router to configure the router as the DHCP server, if necessary. When using a router as the DHCP server, all stereos on the network should use their default configuration (DHCP client).
  - If you are not using a wireless router, you should configure a stereo as a wireless access point, if necessary ([Setting the Fusion PartyBus Device as a Wireless Access Point, page 6](#)). Configuring a stereo as a wireless access point makes that stereo the DHCP server, and all of the other stereos on the network should use their default configuration (DHCP client).
  - If you are not using a network router, not using a stereo as a wireless access point, and there are no other DHCP servers on the network, you should configure one of the stereos as the DHCP server ([Setting the Fusion PartyBus Device as the DHCP Server, page 6](#)).
- 7 Test the network by selecting **GROUPS** to view a list of devices connected to the on the network, and select an option:
  - If any Fusion PartyBus devices are not available to the network, troubleshoot the network ([Network Troubleshooting, page 7](#)).
  - If all Fusion PartyBus devices are available on the network, complete the installation for each stereo, if necessary.

## Network Configuration

**TIP:** You can select the network status icon from any screen to open the network configuration menu.

### Setting the Fusion PartyBus Device as the DHCP Server

If you connected more than two network devices together using a network switch or wireless access point but you did not install a router, you should configure only one Fusion PartyBus stereo to be a DHCP server.

#### NOTICE

Having more than one DHCP server on the network causes instability and poor performance for all devices on the network.

**NOTE:** If you have set up this stereo as a WI-FI ACCESS POINT, it is configured as a DHCP server by default, and no further settings changes are needed ([Setting the Fusion PartyBus Device as a Wireless Access Point, page 6](#)).

- 1 If the device is connected to the network using an Ethernet cable, select **SETTINGS > NETWORK > WI-FI OFF**.
- 2 If the device is connected to the network using an Ethernet cable, select **STATIC IP > SAVE**.
- 3 Select **ADVANCED > DHCP SERVER > DHCP ENABLED > SAVE**.

### Configuring the Stereo for use with a Garmin® Marine Network

You can connect this stereo to a Garmin Marine Network in order to view and control the stereo using a compatible Garmin chartplotter.

**NOTE:** When you configure the stereo for use with a Garmin Marine Network, you are limited to using only Garmin and Fusion devices. You may not be able to use third-party routers, storage devices, or other network products with this stereo directly.

When the stereo is connected to a Garmin Marine Network, you can connect a smartphone to a wireless access point on a connected Garmin chartplotter and use the Fusion-Link app to control the stereo.

You cannot use Wi-Fi networking on a stereo configured for use with a Garmin Marine Network. This functionality is compatible with wired network connections only.

Select **SETTINGS > NETWORK > WI-FI OFF > GARMIN MARINE NETWORK**.

### Setting the Fusion PartyBus Device as a Wireless Access Point

Before you can connect additional Fusion PartyBus devices or smartphones to a Fusion PartyBus device wirelessly, you must configure one device as a wireless access point. This is not necessary if you installed a wireless router or other wireless access point on the network.

**NOTE:** You should not configure this device as a wireless access point if you have a router installed on the network. Doing so may introduce DHCP conflicts and result in poor network performance.

For more detailed configuration instructions, see the owner's manual.

- 1 Select **SETTINGS > NETWORK > WI-FI ACCESS POINT**.
- 2 Select **USE DEFAULTS** and wait for the device to save the network settings.

**NOTE:** After the default settings are saved, you can scroll down to the bottom of the NETWORK menu to view and change the SSID and password assigned to the access point.

**NOTE:** When you configure the stereo as a wireless access point, you can also use the wired network connection without changing any additional settings. The wired and wireless networks are bridged.

### Connecting the Fusion PartyBus Device to a Wireless Access Point

You can connect this device to a wireless access point on a router or compatible Fusion PartyBus device on the network. This device can connect using Wi-Fi Protected Setup (WPS), if it is supported by your access point. This device can connect using Apple Accessory Configuration (WAC) using a supported Apple device.

- 1 Select **SETTINGS > NETWORK > WI-FI CLIENT > SSID**.

A list of wireless access points within range appears.
- 2 Select the Fusion PartyBus wireless access point.
- 3 If necessary, select **PASSWORD**, enter the password, and select **✓**.
- 4 Select **SAVE**.

**NOTE:** When you connect the stereo to a wireless access point, you cannot use the wired network connection.

### Resetting Network Settings

You can reset all network settings for this stereo to the factory default values.

Select  > **SETTINGS** > **NETWORK** > **RESET** > **YES**.

### Advanced Network Configuration

You can perform advanced networking tasks on a Fusion PartyBus device, such as defining DHCP ranges and setting static IP addresses. See the owner's manual for more information.

### Network Troubleshooting

If you cannot see or connect to Fusion PartyBus devices on the network, check the following:

- Verify that only one device, either a stereo or a router, is configured as a DHCP server.
- Verify that all Fusion PartyBus devices, network switches, routers, and wireless access points are connected to the network and turned on.
- Verify that wireless Fusion PartyBus devices are connected to a wireless router or wireless access point on the network.  
**NOTE:** Wired connections are more reliable than wireless connections. If possible, you should connect devices to the network using an Ethernet cable.
- You may experience wireless interference if there are many nearby wireless access points. Change the channel on your router or wireless access point to test for and correct interference.
- Connecting a Bluetooth device to a stereo configured as a wireless access point or client may reduce wireless performance. Disconnect Bluetooth devices to test for and correct interference.
- If you configured static IP addresses, verify that every device has a unique IP address, that the first three sets of numbers in the IP addresses match, and that the subnet masks on every device are identical.
- If you have made configuration changes that might be causing networking issues, reset all network settings to the factory default values.

## Stereo Information

### Specifications

#### General

Weight	750 g (26.5 oz.)
Water resistance	IEC 60529 IPX7 (front of stereo only, when properly installed)
Operating temperature range	From 0 to 50°C (from 32 to 122°F)
Storage temperature range	From -20 to 70°C (from -4 to 158°F)
Input voltage	From 10.8 to 16 Vdc
Current (max.)	15 A
Current (muted)	Less than 900 mA
Current (off)	Less than 200 mA
Fuse	15 A mini blade-type
NMEA 2000 LEN @ 9 Vdc	1 (50 mA)
Bluetooth wireless range	Up to 10 m (30 ft.)
ANT <sup>®</sup> wireless range	Up to 3 m (10 ft.)
Wireless frequencies/ protocols	Wi-Fi 2.4 GHz @ +15 dBm nominal Bluetooth 2.4 GHz @ +10 dBm nominal ANT 2.4 GHz @ +4 dBm nominal
Compass-safe distance	15 cm (5.9 in.)

### On-board, Class D Amplifier

Output music power per channel	4 x 70 W max. 2 ohm
Total output peak power	280 W max.
Output power per channel <sup>1</sup>	4 x 43 W RMS at 14.4 Vdc input, 2 ohm, 10% THD 4 x 26 W RMS at 14.4 Vdc input, 4 ohm, 10% THD
Line output level (max.)	5.5 V (peak to peak)
Aux input level (typical)	1 V RMS

### Tuner frequencies

Tuner	Europe and Australasia	USA	Japan
FM radio frequency range	87.5 to 108 MHz	87.5 to 107.9 MHz	76 to 95 MHz
FM frequency step	50 kHz	200 kHz	50 kHz
AM radio frequency range	522 to 1620 kHz	530 to 1710 kHz	522 to 1620 kHz
AM frequency step	9 kHz	10 kHz	9 kHz

## Stereo Dimension Drawings

### Side Dimensions

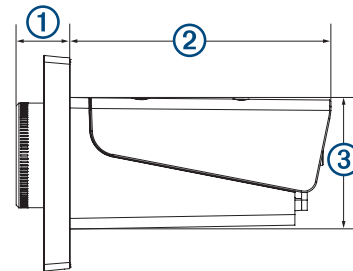

①	20.4 mm (0.8 in.)
②	99 mm (3.9 in.)
③	50 mm (1.97 in.)

### Top Dimensions

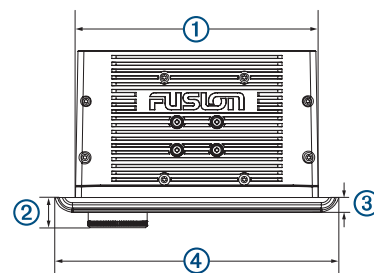

①	164 mm (6.5 in.)
②	20.4 mm (0.8 in.)
③	10 mm (0.39 in.)
④	192 mm (7.56 in.)

### Software Updates

For best results, you should update the software in all Fusion devices at the time of installation to ensure compatibility.

You can update the software using the Fusion-Link remote control app on your compatible Apple or Android™ device, or using a USB flash drive.

<sup>1</sup> The stereo may limit the output power to prevent the amplifier from overheating, and to maintain the audio dynamics.

To download the app and update the device software, go to the Apple App Store<sup>SM</sup> or the Google Play<sup>TM</sup> store. For software updates and instructions on updating the device using the USB flash drive, go to the device product page at [www.fusionentertainment.com/marine](http://www.fusionentertainment.com/marine).

## 物質宣言

部件名称	有毒有害物质或元素					
	铅	汞	镉	六价铬	多溴联苯	多溴二苯醚
印刷电路板组件	X	○	○	○	○	○
屏幕/背光	X	○	○	○	○	○
金属零件	X	○	○	○	○	○
电缆 电缆组件 连接器	X	○	○	○	○	○

本表格依据 SJ/T11364 的规定编制。

○: 代表此种部件的所有均质材料中所含的该种有害物质均低于 (GB/T26572) 规定的限量

X: 代表此种部件所用的均质材料中, 至少有一类材料其所含的有害物质高于

(GB/T26572) 规定的限量

\*該產品說明書應提供在環保使用期限和特殊標記的部分詳細講解產品的擔保使用條件。



## 低功率電波輻射電機管理宣告

本產品謹遵循中華民國國家通訊傳播委員會所頒布電信管理法，並經驗證通過合格，請使用者遵循相關電信法規以避免違反規定受罰。若使用者欲攜帶本機至其他國家應用，也請遵循該地區或國家之相關法令限制。根據國家通訊傳播委員會低功率射頻器材技術規範規定

3.8.2 章節：

取得審驗證明之低功率射頻器材，非經核准，公司、商號或使用者均不得擅自變更頻率、加大功率或變更原設計之特性及功能。

低功率射頻器材之使用不得影響飛航安全及干擾合法通信；經發現有干擾現象時，應立即停用，並改善至無干擾時方得繼續使用。

前項合法通信，指依電信法規定作業之無線電通信。低功率射頻器材須忍受合法通信或工業、科學及醫療用電波輻射性電機設備之干擾。

## 連絡地址

製造銷售:台灣國際航電股份有限公司

聯絡地址:新北市汐止區樟樹二路 68 號

電話:(02)2642-8999

客服專線:(02)2642-9199